

# INSERT MANUAL

**2015.16 Concert Season**

The Royal Conservatory

**Advanced winter weaponry**  
The proliferation of snowfall gadgets - from launchers to blasters to snowbombs - has altered the seasonal snow-fact landscape

**THE GLOBE AND MAIL**  
CANADA'S NATIONAL NEWSPAPER • TUESDAY, DECEMBER 27, 2015 • [globeandmail.com](http://globeandmail.com)

**Fed rate hike first since economic crisis**  
The 0.25-per-cent increase signals confidence in emerging U.S. economy that could translate into a boost for Canadian exports

**MEANWHILE**  
The U.S. Federal Reserve's decision to raise interest rates is a move that will have a ripple effect on the Canadian economy. The Bank of Canada is expected to follow suit in the near future. The Fed's move is seen as a sign of confidence in the U.S. economy, which could lead to a stronger Canadian dollar and increased exports.



**GOING COASTAL**  
After trawling waters during the Harper era, Canada's marine conservation effort is shifting into high gear. The new Liberal government has confirmed that it will set aside 85 per cent of the country's marine waters for protection by 2020 to meet commitments under the UN Convention on Biodiversity.

**Quake confirmed as largest caused by fracking in B.C.**  
Canadian laser begins trek to scope and scoop asteroid

**SPACE**  
A Canadian laser system is set to launch in 2017 to track and identify near-Earth asteroids. The system, called the Asteroid Thermal Characterization and Detection System (ATCDS), will use a laser to measure the thermal properties of asteroids, helping scientists determine their composition and potential threat to Earth.

**POWER YOU WANT. ROOM YOU NEED.**  
THE 2015 Acura MDX. STARTING FROM \$22,991\*

**MDX**

**CNE GUIDEBOOK 2015**

**BASKETS**  
Innovative. Intelligent. Irresistible.

**DOLL**  
Brilliant ideas. Save big.

**\$549.99**

**RONA HOME & GARDEN**

**EXFL**  
AGA KHAN MUSEUM

**GET UP TO 20% OFF**  
WITH ANY PURCHASE OF SPECIAL ORDER KITCHEN CABINETS



## CONTENTS



### RATES

- 3 MECHANICAL INSERTS
- 3 HAND INSERTS

### SPECIFICATIONS

- 4 MECHANICAL INSERTS

### DISTRIBUTION

- 6 NATIONAL MAP
- 7 ONTARIO MAP
- 8 TORONTO REGION MAP
- 9 TORONTO REGION FSA LIST
- 11 DISTRIBUTION NETWORK

### SPECIAL PRODUCTS

- 12 POST-IT NOTES
- 13 SLEEVES
- 14 TAGS
- 15 OUTSERTS

### SHIPPING INSTRUCTIONS

- 16 MECHANICAL INSERTS
- 18 HAND INSERTS / SPECIAL PRODUCTS

### CONTACT INFORMATION

- 20 ADVERTISING/THIRD PARTY AD MAGAZINES



## INSERT RATES

### MECHANICAL INSERT RATES

NUMBER OF PAGES	COST PER THOUSAND	
	GENERAL (GROSS)	RETAIL (NET)
2	\$78.86	\$67.03
4-8	\$102.41	\$87.06
12-16	\$108.43	\$92.16
20-24	\$115.00	\$97.75
28-32	\$120.48	\$102.42
36+	\$138.52	\$117.75

### MINIMUM MECHANICAL INSERT RATES

PER PLANT	MINIMUM \$	
	MON-FRI (NET)	SATURDAY (NET)
Toronto	\$5,000	\$7,500
Montreal	\$2,000	\$2,500*
Halifax	\$2,000	\$2,500*
Estevan	\$2,000	\$2,500*
Calgary	\$2,000	\$2,500*
Vancouver	\$2,000	\$2,500*
National (All Plants)	\$10,000	\$15,000

\*subject to availability

**Note:** All insert products must meet our specifications and the plant minimum must be met in order to guarantee the insertion date.

### HAND INSERT RATES

Product Weight	Cost Per Thousand (NET)
Under 450 grams	\$300.00
Over 450 grams*	\$400.00

\*Up to a maximum of 700 grams

#### Late delivery

The Globe and Mail will no longer accept late insert material. Any material arriving less than three business days prior to insertion will be rescheduled to the next available date.

#### Spoilage

Please supply an additional 1.5% for mechanical inserts and 2% for hand-inserts for spoilage.

#### Third party advertising

Rates on this page do not apply to inserts containing third party advertising. For a quote - please send a copy of your magazine to:

Michael Anderson  
 c/o The Globe and Mail  
 444 Front Street West  
 Toronto, ON M5V 2S9  
 phone: 416-585-5455  
 email: mwanderson@globeandmail.com

#### PLEASE NOTE:

THE INSERT MATERIAL DEADLINE IS FIVE BUSINESS DAYS PRIOR TO THE RUN DATE. SHIPMENTS ARRIVING MORE THAN SEVEN BUSINESS DAYS PRIOR TO INSERTION WILL BE REFUSED.

The client should supply the recommended press run amount (plus spoilage) to ensure that all copies of the newspaper are inserted. Please note that our press run numbers can fluctuate on a daily basis due to market activity. The airline copies are not inserted in the Toronto market and these amounts are not included in the press run figures. Contact your sales representative for the latest press run figures.

All quotations exclude freight to The Globe and Mail plants. The client and/or agency will arrange for delivery and prepay all delivery expenses (including any customs brokerage fees).

All insert material must arrive at our printing plants during normal receiving hours no later than three business days prior to the insertion date. No deliveries will be accepted on Saturday, Sunday or statutory holidays.

Insert shipments do not require prior appointments for delivery except for the Vancouver Plant. Please call 604-527-9230 to make an appointment. You must provide the client name, insert title and run date. The shipment must be properly labelled and must arrive at our plants in good condition; otherwise the shipment will not be unloaded.

Any insert that is received less than three business days prior to the insertion date or is improperly labelled or is received in a damaged condition will be cancelled and/or rescheduled. Any expenses incurred by The Globe and Mail will be charged to the client.

Any insert material remaining after the print run will be recycled immediately after the completion of insertion unless written arrangements are made at least five business days prior to the insertion date with The Globe and Mail. Pick-up must be completed within two business days of the insertion date.

Any cancelled inserts not removed from the plants by the client within three days of cancellation will be recycled unless prior written arrangements for re-scheduling or removal by the client are made. Late cancellation charges up to 50% of the original order will apply to all inserts cancelled less than five days prior to insertion.

The Globe and Mail reserves the right to reschedule the distribution date in the event of production problems or delays, inclement weather or other factors outside of its normal control that would result in a reduced delivery efficiency of The Globe and Mail newspaper. The Globe and Mail will promptly notify the client of any such circumstances and a new distribution date will be established at that time. Pricing will remain firm in the event of such an occurrence.

Industry standards allow for a margin of error up to 3% for the insertion and distribution of inserts.

#### Shipping Instructions

Mechanical Inserts – see pages 16 and 17.  
 Hand Inserts – see pages 18 and 19.



## MECHANICAL INSERT SPECIFICATIONS

Minimum Size: 4" wide x 7" deep.

Maximum size: 10" wide x 10.5" deep.

Maximum Weight: Up to 220 grams for a mechanical insert.

Larger products may be hand inserted for an additional charge.

Maximum number of pages for all digest size inserts is 32 pages.

### MINIMUM PAPER WEIGHT

#### Number of Pages

2 pages	7 pt. card stock
4 pages	70 lb stock
6 pages	60 lb stock
8 pages	50 lb stock
12+ pages	45 lb stock

**Note:** All newsprint products must be a minimum of 8 pages on 30 lbs stock or heavier and must be quarter-folded. All trimmed booklets must be quarterfolded, stitched or bound to prevent product separation during insertion. Inserts must have one closed edge to ensure proper insertion by our equipment. We do not accept accordion-style or plastic wrapped inserts for mechanical insertion. All inserts with perforations or die cuts must be tested prior to insertion.

### MINIMUM SIZE

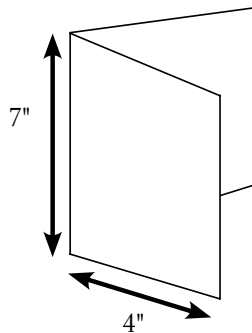

### MAXIMUM SIZE

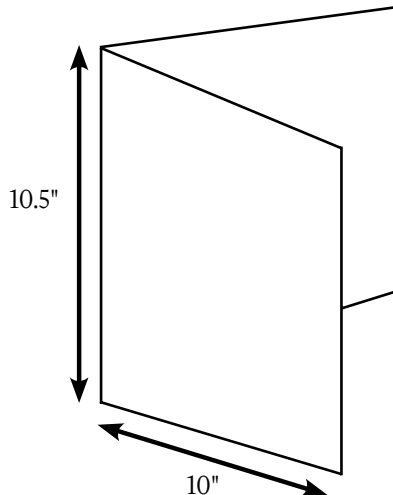

### Coatings

**Please note:** certain AQ (Aqueous) coatings, such as SOFT TOUCH, that create a wax-like finish when applied while printing inserts intended for mechanical insertion may cause feeding problems on our inserting machines and possible production delays. These coated products tend to stick together and may result in multiple copies being inserted into the newspaper. In addition, some high gloss UV (ultra-violet) coatings may cause the opposite result by creating a slippery product that may slide easily out of the newspaper during insertion or delivery. If any insert or magazine product creates production problems or delays that would result in a reduced delivery efficiency of the Globe and Mail, we reserve the right to remove the product from insertion. The Globe and Mail will promptly notify the client of any such circumstances and a new distribution date will be established at that time. Pricing will remain firm in the event of such an occurrence. If you are unsure about the coating on your insert, please check with your printer and have them send at least five stock samples with the intended coating to The Globe and Mail for review.

### Blow-In Inserts

Supplied inserts cannot contain blow-in inserts.

### Envelopes

Envelopes cannot be less than 5" deep x 7" wide. Envelope contents must be of a uniform size and the envelope must be sealed.

### Scented Inserts

Sales representatives with customers wanting to insert scented products must notify Michael Anderson at 416-585-5455 or email [mwanderson@globeandmail.com](mailto:mwanderson@globeandmail.com).

### Samples/Mock-Ups

All insert reservations must be accompanied by a mock-up or sample for approval within two weeks of booking. Any insert reservation that does not have an approved mock-up or sample provided is subject to cancellation anytime after two weeks from the date of booking. The mock-up does not have to be printed, but must be on the same paper stock, and be trimmed and folded to the final size of the insert. The sample can be either the final printed version of the insert or a copy of a previously inserted product that was approved for mechanical insertion. If your insert is a repeat of the same design and size of a previously approved insert, you must provide the run date of the previous insert in order to confirm your order.

**All insert samples/mock-ups should be sent to:**

**Michael Anderson**  
**c/o The Globe and Mail,**  
**444 Front Street West**  
**Toronto, Ontario M5V 2S9**

**Please include a contact name, phone number and email address with your sample. Inserts that do not meet our specifications may be hand inserted for home delivery only. An additional handling fee will apply.**



## STANDARD MECHANICAL INSERT DESIGNS

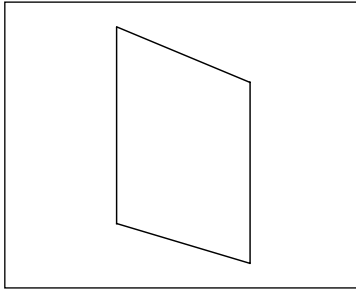

2 PAGE – NO FOLD  
FLAT SINGLE SHEET  
MINIMUM PAPER STOCK: 7 PT CARD  
STOCK

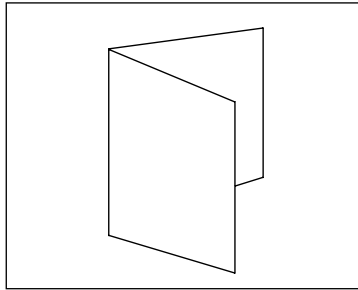

4 PAGE – ONE FOLD  
SIMPLE FOLD  
MINIMUM PAPER STOCK: 70 LBS

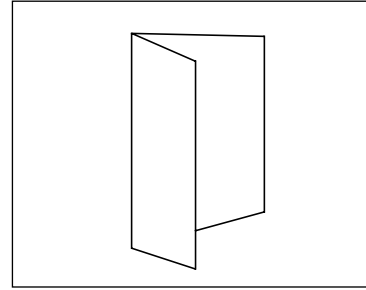

4 PAGE – ONE FOLD  
SHORT FOLD (MINIMUM 4")  
MINIMUM PAPER STOCK: 70 LBS

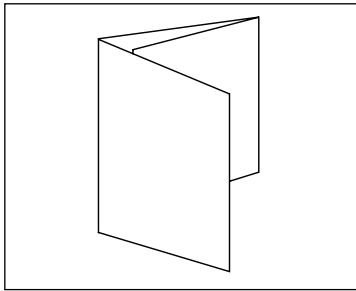

6 PAGE – TWO FOLDS  
BARREL/LETTER FOLD  
MINIMUM PAPER STOCK: 60 LBS

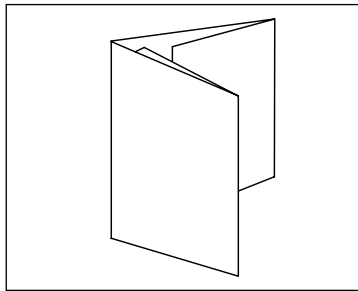

8 PAGE – THREE FOLDS  
GATEFOLD  
MINIMUM PAPER STOCK: 50 LBS

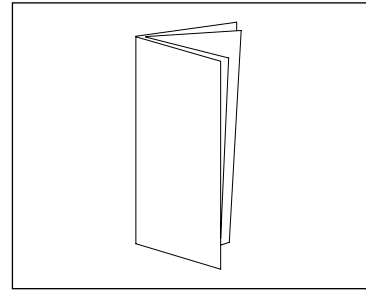

8 PAGE – TWO FOLDS  
SIGNATURE/BOOKLET  
MINIMUM PAPER STOCK: 50 LBS

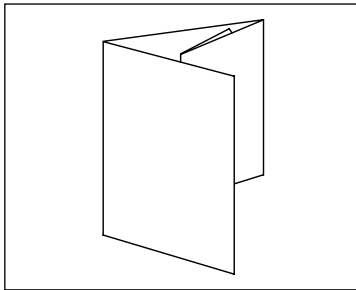

8 PAGE – THREE FOLDS  
ROLL FOLD  
MINIMUM PAPER STOCK: 50 LBS

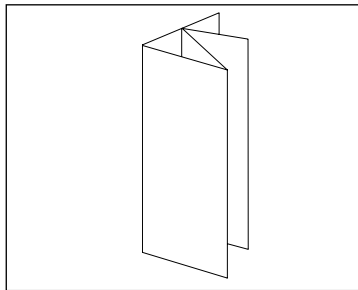

8 PAGE – THREE FOLDS  
PARALLEL FOLD  
MINIMUM PAPER STOCK: 50 LBS

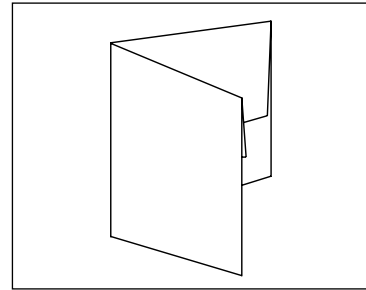

8 PAGE – TWO FOLDS  
FRENCH FOLD  
MINIMUM PAPER STOCK: 50 LBS

## UNACCEPTABLE MECHANICAL INSERT DESIGNS

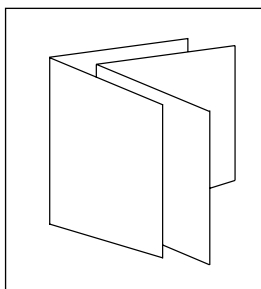

LOOSE BOOKLET

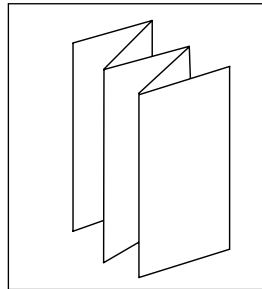

ACCORDION FOLD

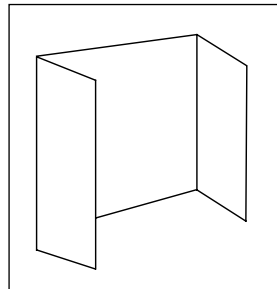

OPEN GATEFOLD

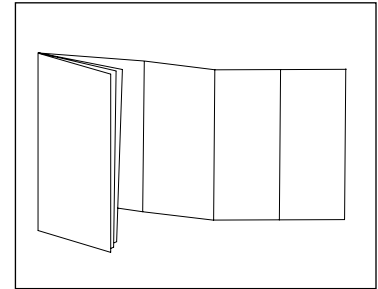

MULTIPLE COVER GATEFOLD



## NATIONAL MAP

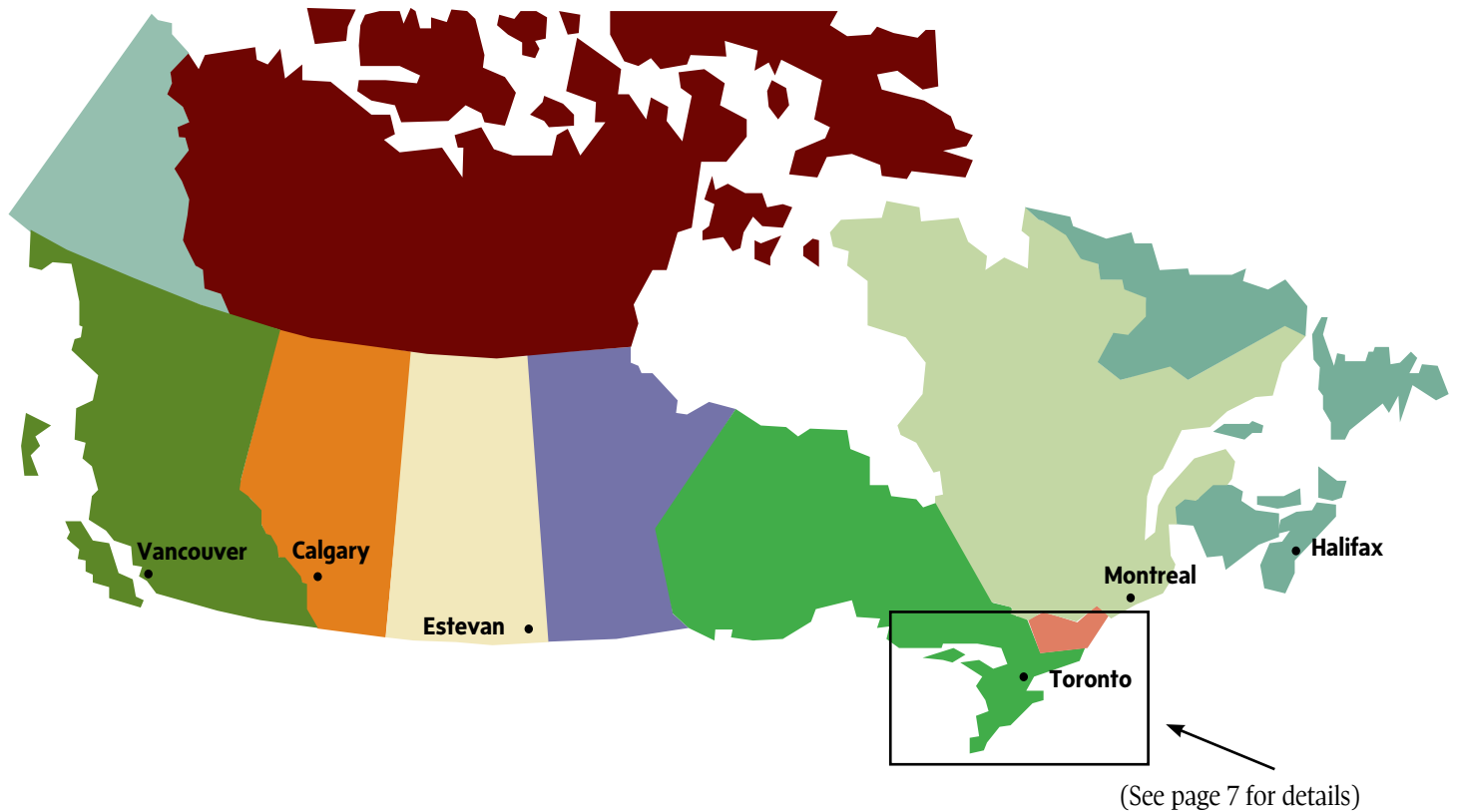

## National Edition

### TORONTO PLANT

(See page 7 for details)

**Toronto | TOR**

**Greater Toronto | GTO**

**Greater Ontario | GON**

### MONTREAL PLANT

**Ottawa | OTT**

Brockville, Cornwall, Nepean, Ottawa, Prescott

**Quebec | QUE**

Hull, Montreal, Quebec City

### HALIFAX PLANT

**Maritimes | MAR**

Nova Scotia, New Brunswick, Prince Edward Island

### ESTEVAN PLANT

**Manitoba | MAN**

Brandon, Winnipeg

**Saskatchewan | SAS**

Regina, Saskatoon

### CALGARY PLANT

**Edmonton | EDM**

Edmonton

**Calgary | CAL**

Calgary, Lethbridge, Medicine Hat, Red Deer

### VANCOUVER PLANT

**Vancouver | VAN**

Abbotsford, Burnaby, Chilliwack, Coquitlam, Kamloops, Kelowna, Maple Ridge, New Westminster, North Vancouver, Penticton, Richmond, Surrey, Vancouver, West Vancouver, Vernon

**Victoria | VIC**

Nanaimo, Victoria



## ONTARIO MAP

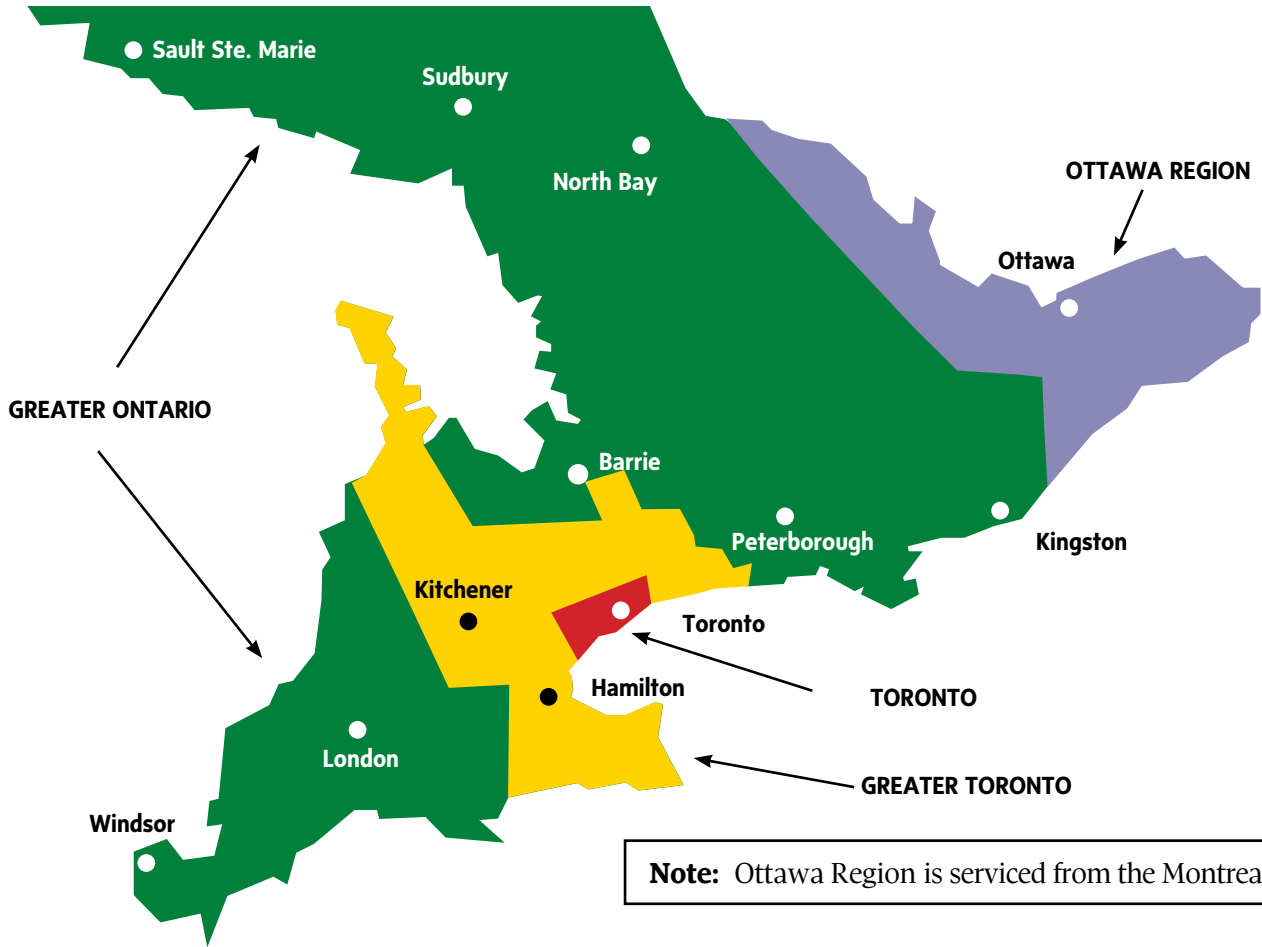

### Metro Edition TORONTO PLANT

#### TORONTO - TOR

TOR.....TORONTO

#### GREATER TORONTO - GTO

GTO.....AJAX  
 GTO.....AURORA  
 GTO.....BRAMPTON  
 GTO.....BURLINGTON  
 GTO.....CAMBRIDGE  
 GTO.....FORT ERIE  
 GTO.....GEORGETOWN  
 GTO.....GUELPH  
 GTO.....HAMILTON  
 GTO.....KITCHENER  
 GTO.....MARKHAM  
 GTO.....MILTON

GTO.....MISSISSAUGA  
 GTO.....NEWMARKET  
 GTO.....NIAGARA FALLS  
 GTO.....OAKVILLE  
 GTO.....ORANGEVILLE  
 GTO.....OSHAWA  
 GTO.....PICKERING  
 GTO.....RICHMOND HILL  
 GTO.....ST CATHERINES  
 GTO.....THORNHILL  
 GTO.....WATERLOO  
 GTO.....WHITBY  
 GTO.....WOODBRIE

#### GREATER ONTARIO - GON

GON.....BARRIE  
 GON.....BELLEVILLE  
 GON.....BOWMANVILLE  
 GON.....BRANTFORD  
 GON.....CHATHAM  
 GON.....COBOURG  
 GON.....HUNTSVILLE  
 GON.....KINGSTON  
 GON.....LINDSAY  
 GON.....LONDON  
 GON.....NORTH BAY  
 GON.....ORILLIA  
 GON.....PETERBOROUGH  
 GON.....PORT HOPE  
 GON.....SARNIA  
 GON.....SAULT STE MARIE  
 GON.....STRATFORD  
 GON.....SUDBURY  
 GON.....TRENTON  
 GON.....WINDSOR  
 GON.....WOODSTOCK



## TORONTO REGION MAP

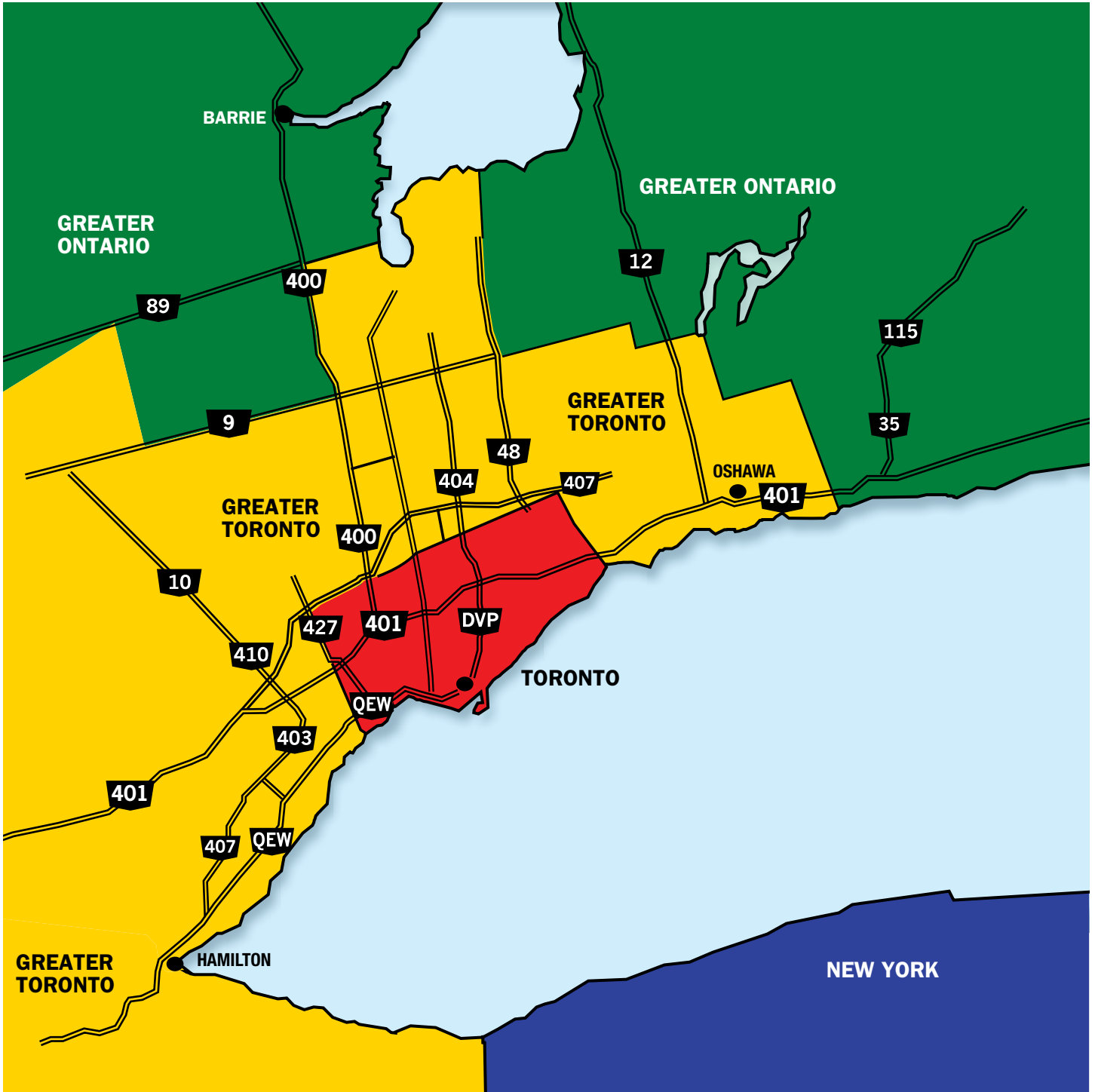





## TORONTO (TOR)

M1B	SCARBOROUGH
M1C	SCARBOROUGH
M1E	SCARBOROUGH
M1G	SCARBOROUGH
M1H	SCARBOROUGH
M1J	SCARBOROUGH
M1K	SCARBOROUGH
M1L	SCARBOROUGH
M1M	SCARBOROUGH
M1N	SCARBOROUGH
M1P	SCARBOROUGH
M1R	SCARBOROUGH
M1S	SCARBOROUGH
M1T	SCARBOROUGH
M1V	SCARBOROUGH
M1W	SCARBOROUGH
M1X	SCARBOROUGH
M2H	NORTH YORK
M2J	NORTH YORK
M2K	NORTH YORK
M2L	NORTH YORK
M2M	NORTH YORK
M2N	NORTH YORK
M2P	NORTH YORK
M2R	WILLOWDALE
M3A	NORTH YORK
M3B	DON MILLS
M3C	DON MILLS
M3H	NORTH YORK
M3J	NORTH YORK
M3K	DOWNSVIEW
M3L	DOWNSVIEW
M3M	DOWNSVIEW
M3N	DOWNSVIEW
M4A	NORTH YORK
M4B	EAST YORK
M4C	EAST YORK
M4E	EAST YORK
M4G	EAST YORK
M4H	EAST YORK
M4J	EAST YORK
M4K	EAST YORK
M4L	EAST YORK
M4M	EAST TORONTO
M4N	CENTRAL TORONTO
M4P	CENTRAL TORONTO
M4R	CENTRAL TORONTO
M4S	CENTRAL TORONTO
M4T	CENTRAL TORONTO
M4V	CENTRAL TORONTO
M4W	DOWNTOWN

M4X	DOWNTOWN
M4Y	DOWNTOWN
M5A	DOWNTOWN
M5B	DOWNTOWN
M5C	DOWNTOWN
M5E	DOWNTOWN
M5G	DOWNTOWN
M5H	DOWNTOWN
M5J	DOWNTOWN
M5K	DOWNTOWN
M5L	DOWNTOWN
M5M	NORTH YORK
M5N	CENTRAL TORONTO
M5P	CENTRAL TORONTO
M5R	CENTRAL TORONTO
M5S	DOWNTOWN
M5T	DOWNTOWN
M5V	DOWNTOWN
M5X	DOWNTOWN
M6A	NORTH YORK
M6B	NORTH YORK
M6C	YORK
M6E	YORK
M6C	YORK
M6E	YORK
M6G	DOWNTOWN
M6H	WEST TORONTO
M6J	WEST TORONTO
M6K	WEST TORONTO
M6L	NORTH YORK
M6M	YORK
M6N	YORK
M6P	WEST TORONTO
M6R	WEST TORONTO
M6S	WEST TORONTO
M7A	QUEENS PARK
M8V	ETOBICOKE
M8W	ETOBICOKE
M8X	ETOBICOKE
M8Y	ETOBICOKE
M8Z	ETOBICOKE
M9A	ETOBICOKE
M9B	ETOBICOKE
M9C	ETOBICOKE
M9L	NORTH YORK
M9M	NORTH YORK
M9N	WESTON
M9P	ETOBICOKE
M9R	ETOBICOKE
M9V	ETOBICOKE
M9W	ETOBICOKE

FSAs included within a specific delivery zone are subject to change.



## GREATER TORONTO (GTO)

L1E	COURTICE	L4Z	MISSISSAUGA	L8L	HAMILTON
L1G	OSHAWA	L5A	MISSISSAUGA	L8M	HAMILTON
L1H	OSHAWA	L5B	MISSISSAUGA	L8N	HAMILTON
L1J	OSHAWA	L5C	MISSISSAUGA	L8P	HAMILTON
L1K	OSHAWA	L5E	MISSISSAUGA	L8R	HAMILTON
L1L	OSHAWA	L5G	MISSISSAUGA	L8S	HAMILTON
L1M	WHITBY	L5H	MISSISSAUGA	L8T	HAMILTON
L1N	WHITBY	L5J	MISSISSAUGA	L8V	HAMILTON
L1P	WHITBY	L5K	MISSISSAUGA	L8W	HAMILTON
L1R	WHITBY	L5L	MISSISSAUGA	L9A	HAMILTON
L1S	AJAX	L5M	MISSISSAUGA	L9B	HAMILTON
L1T	AJAX	L5N	MISSISSAUGA	L9C	HAMILTON
L1V	PICKERING	L5P	MISSISSAUGA (YYZ)	L9G	ANCASTER
L1W	PICKERING	L5R	MISSISSAUGA	L9H	DUNDAS
L1X	PICKERING	L5S	MISSISSAUGA	L9K	ANCASTER
L1Y	PICKERING	L5T	MISSISSAUGA	L9L	PORT PERRY
L1Z	AJAX	L5V	MISSISSAUGA	L9N	HOLLAND LANDING
L2A	FORT ERIE	L5W	MISSISSAUGA	L9P	UXBRIDGE
L2E	NIAGARA FALLS	L6A	MAPLE	L9T	MILTON
L2G	NIAGARA FALLS	L6B	MARKHAM	L9V	ORANGEVILLE
L2H	NIAGARA FALLS	L6C	MARKHAM	L9W	ORANGEVILLE
L2J	NIAGARA FALLS	L6E	MARKHAM	N1A	DUNNVILLE
L2M	ST CATHERINES	L6G	MARKHAM	N1C	GUELPH
L2N	ST CATHERINES	L6H	OAKVILLE	N1E	GUELPH
L2P	ST CATHERINES	L6J	OAKVILLE	N1G	GUELPH
L2R	ST CATHERINES	L6K	OAKVILLE	N1H	GUELPH
L2S	ST CATHERINES	L6L	OAKVILLE	N1K	GUELPH
L2T	ST CATHERINES	L6M	OAKVILLE	N1L	GUELPH
L2V	ST CATHERINES	L6P	BRAMPTON	N1M	FERGUS
L2W	ST CATHERINES	L6R	BRAMPTON	N1P	CAMBRIDGE
L3B	WELLAND	L6S	BRAMPTON	N1R	CAMBRIDGE
L3C	WELLAND	L6T	BRAMPTON	N1S	CAMBRIDGE
L3K	PORT COLBORNE	L6V	BRAMPTON	N1T	CAMBRIDGE
L3M	GRIMSBY	L6W	BRAMPTON	N2A	KITCHENER
L3P	MARKHAM	L6X	BRAMPTON	N2B	KITCHENER
L3R	MARKHAM	L6Y	BRAMPTON	N2C	KITCHENER
L3S	MARKHAM	L6Z	BRAMPTON	N2E	KITCHENER
L3T	THORNHILL	L7A	BRAMPTON	N2G	KITCHENER
L3X	NEWMARKET	L7B	KING CITY	N2H	KITCHENER
L3Y	NEWMARKET	L7C	CALEDON	N2J	WATERLOO
L3Z	BRADFORD	L7E	BOLTON	N2K	WATERLOO
L4A	STOUFFVILLE	L7G	GEORGETOWN	N2L	WATERLOO
L4B	RICHMOND HILL	L7J	ACTON	N2M	KITCHENER
L4C	RICHMOND HILL	L7K	CALEDON VILLAGE	N2N	KITCHENER
L4E	RICHMOND HILL	L7L	BURLINGTON	N2P	KITCHENER
L4G	AURORA	L7M	BURLINGTON	N2R	KITCHENER
L4H	WOODBIDGE	L7N	BURLINGTON	N2T	WATERLOO
L4J	THORNHILL	L7P	BURLINGTON	N2V	WATERLOO
L4K	CONCORD	L7R	BURLINGTON	N3B	ELMIRA
L4L	WOODBIDGE	L7S	BURLINGTON	N3C	CAMBRIDGE
L4P	KESWICK	L7T	BURLINGTON	N3E	CAMBRIDGE
L4S	RICHMOND HILL	L8E	HAMILTON	N3H	CAMBRIDGE
L4T	MISSISSAUGA	L8G	HAMILTON	N3W	CALEDONIA
L4V	MISSISSAUGA	L8H	HAMILTON	N3Y	SIMCOE
L4W	MISSISSAUGA	L8J	HAMILTON	N4K	OWEN SOUND
L4X	MISSISSAUGA	L8K	HAMILTON	N4N	HANOVER
L4Y	MISSISSAUGA				

FSAs included within a specific delivery zone are subject to change.



## INSERT DISTRIBUTION NETWORK

PLANT/ZONE	REGION	DELIVERY
<b>TORONTO</b>		
<b>METRO EDITION</b>		
TOR	TORONTO	FULL/HD/FSA
GTO	GREATER TORONTO	FULL/HD/FSA
GON	GREATER ONTARIO	FULL
<b>MONTREAL</b>		
<b>OTTAWA/QUEBEC</b>		
OTT	OTTAWA	FULL/HD
QUE	QUEBEC	FULL/HD
<b>HALIFAX</b>		
<b>ATLANTIC CANADA</b>		
MAR	MARITIMES	FULL/HD
<b>ESTEVAN</b>		
<b>PRAIRIE</b>		
MAN	MANITOBA	FULL/HD
SAS	SASKATCHEWAN	FULL/HD
<b>CALGARY</b>		
<b>ALBERTA</b>		
EDM	EDMONTON	FULL/HD
CAL	CALGARY	FULL/HD
<b>VANCOUVER</b>		
<b>BRITISH COLUMBIA</b>		
VAN	VANCOUVER	FULL/HD
VIC	VICTORIA	FULL/HD
<b>DELIVERY OPTIONS</b>		
FULL	FULL DELIVERY (HOME DELIVERY/SINGLE COPY)	MECHANICAL ONLY
HD	HOME DELIVERY	MECHANICAL/HAND
FSA	FORWARD SORTATION AREA	HAND ONLY



## SPECIAL PRODUCTS - POST-IT® NOTES

- Monday through Friday (excluding last Friday of every month)
- Home Delivery Only
- Minimum Order 25,000
- Four weeks notice required
- Rates are CPM (net)

3" x 4"	25,000	50,000	100,000
1 Spot Colour	\$195.00	\$185.00	\$180.00
2 Spot Colours	\$200.00	\$190.00	\$185.00
3/4 Spot Colours	\$210.00	\$195.00	\$190.00
Process Colour	\$215.00	\$200.00	\$195.00

Imprint Area: 2 9/16" deep x 3 5/8" wide

4" x 6"	25,000	50,000	100,000
1 Spot Colour	\$205.00	\$190.00	\$185.00
2 Spot Colours	\$220.00	\$195.00	\$190.00
3/4 Spot Colours	\$230.00	\$200.00	\$195.00
Process Colour	\$240.00	\$205.00	\$200.00

Imprint Area: 3 5/8" deep x 5 13/16" wide

No bleeds. Paper available in white, yellow, pink, green, blue, cream or gray. Digital files must be provided four weeks prior to run date. Additional charges will apply if manufacturer is required to make adjustments to supplied art. Price includes printing, handling and delivery. Die cutting for non-standard shapes extra. All prices are net. 50% surcharge on rates not supported by ROP advertising.

**If client provides their own post-it® notes, there will be a handling fee of \$200/M net for regular distribution.**

Product supplied must meet Globe and Mail standards. Please provide a sample or mock-up for approval. Post-it notes must be supplied in pads of 50. Product must arrive five to seven business days prior to insertion. For shipping instructions, please see pages 18-19.

Contact Michael Anderson – 416-585-5455 or [mwanderson@globeandmail.com](mailto:mwanderson@globeandmail.com) for details.





## SPECIAL PRODUCTS – SLEEVES

- Monday through Friday (excluding last Friday of every month)
- Home Delivery Only

- Minimum Order 25,000
- Rates are CPM (net)
- Six weeks notice required

### Sleeves

1 SIDE	25,000	50,000	100,000
1 Spot Colour	\$375.00	\$330.00	\$310.00
2 Spot Colours	\$415.00	\$350.00	\$325.00
3 Spot Colours	\$470.00	\$385.00	\$340.00
4 Spot Colours	\$540.00	\$420.00	\$355.00
Process Colour	N/A	\$550.00	\$440.00

2 SIDES - SAME	25,000	50,000	100,000
1 Spot Colour	\$390.00	\$350.00	\$325.00
2 Spot Colours	\$430.00	\$365.00	\$340.00
3 Spot Colours	\$485.00	\$395.00	\$350.00
4 Spot Colours	\$555.00	\$430.00	\$365.00
Process Colour	N/A	\$565.00	\$460.00

2 SIDES - DIFFERENT	25,000	50,000	100,000
1 Spot Colour	\$430.00	\$365.00	\$340.00
2 Spot Colours	\$480.00	\$395.00	\$350.00
3 Spot Colours	\$585.00	\$445.00	\$380.00
4 Spot Colours	\$695.00	\$505.00	\$400.00
Process Colour	N/A	\$625.00	\$495.00

Printed on white opaque or clear plastic (22" wide x 10" deep x .001 mil thick). Imprint Area: 16" wide x 9.5" deep. Digital files must be provided six weeks prior to run date. Additional charges will apply if manufacturer is required to make adjustments to supplied material. Prices include printing, handling and delivery. All prices are net. 50% surcharge on rates not supported by ROP advertising.

**If client provides their own sleeves, there will be a handling fee of \$200/M net for regular distribution.**

Product supplied must meet Globe and Mail standards. Please provide a sample or mock-up for approval. Sleeves must be supplied in bundles of 100. Product must arrive five to seven business days prior to insertion. For shipping instructions, please see pages 18-19.

Contact Michael Anderson – 416-585-5455 or [mwanderson@globeandmail.com](mailto:mwanderson@globeandmail.com) for details.





## SPECIAL PRODUCTS - TAGS

- Monday through Friday (excluding last Friday of every month)
- Home Delivery Only

- Minimum Order 12,500
- Six weeks notice required

■ Rates are CPM (net)

1 SIDE	12,500	25,000	50,000	100,000
Process Colour	\$350.00	\$295.00	\$270.00	\$240.00

2 SIDES	12,500	25,000	50,000	100,000
Process Colour	\$360.00	\$305.00	\$280.00	\$250.00

Tag size: 3" wide x 3.5" deep. Imprint Area: 2.5" wide x 3" deep. Digital files must be provided six weeks prior to run date. Printed on one or two sides on 15 point coated stock. Additional charges will apply if manufacturer is required to make adjustments to supplied material. Price includes printing, attaching the tag to the newspaper with an elastic band, and delivery. Die cutting for non-standard tags extra. All prices are net. 50% surcharge on rates not supported by ROP advertising.

**If client provides their own tags, there will be a handling fee of \$200/M net for regular distribution.**

Product supplied must meet Globe and Mail standards. Please provide a sample or mock-up for approval. Tags must be supplied in bundles of 50. Product must arrive five to seven business days prior to insertion. For shipping instructions, please see pages 18-19.

Contact Michael Anderson – 416-585-5455 or [mwanderson@globeandmail.com](mailto:mwanderson@globeandmail.com) for details.





## SPECIAL PRODUCTS - OUTSERTS

- Monday through Friday (excluding last Friday of every month)
- Home Delivery Only

- Die cutting extra
- Six weeks notice required

- Rates are CPM (net)

### METRO

Process Colour

See your sales agent for rates.

Outsert size: Front panel 5¾" x 11"; back panel 10½" x 11". Digital files must be provided six weeks prior to run date. Printed on one side on 100# coated stock. Additional charges will apply if manufacturer is required to make adjustments to supplied material. Price includes printing, attaching the outsert to the newspaper, and delivery. Die cutting extra. All prices are net. 50% surcharge on rates not supported by ROP advertising.

### NATIONAL

Process Colour

See your sales agent for rates.

**If client provides their own outserts, there will be a handling fee of \$325/M net for regular distribution.**

Product supplied must meet Globe and Mail standards. Please provide a sample or mock-up for approval. Outserts must be supplied cross-tied in bundles of 50. Product must arrive five to seven business days prior to insertion. For shipping instructions, please see pages 18-19.

Contact Michael Anderson – 416-585-5455 or [mwanderson@globeandmail.com](mailto:mwanderson@globeandmail.com) for details.





## SHIPPING INSTRUCTIONS – MECHANICAL INSERTS

### PLEASE NOTE:

**THE INSERT MATERIAL DEADLINE IS FIVE BUSINESS DAYS PRIOR TO THE RUN DATE. SHIPMENTS ARRIVING MORE THAN SEVEN BUSINESS DAYS PRIOR TO INSERTION WILL BE REFUSED.**

The client should supply the recommended press run amount (plus spoilage) to ensure that all copies of the newspaper are inserted. Please note that our press run numbers can fluctuate on a daily basis due to market activity. The airline copies are not inserted in the Toronto market and these amounts are not included in the press run figures. Contact your sales representative for the latest press run figures.

All quotations exclude freight to The Globe and Mail plants. The client and/or agency will arrange for delivery and prepay all delivery expenses (including any customs brokerage fees).

All insert material must arrive at our printing plants during normal receiving hours no later than three business days prior to the insertion date. No deliveries will be accepted on Saturday, Sunday or statutory holidays.

Insert shipments do not require prior appointments for delivery except for the Vancouver Plant. Please call 604-527-9230 to make an appointment. You must provide the client name, insert title and run date. The shipment must be properly labelled and must arrive at our plants in good condition; otherwise the shipment will not be unloaded.

Any insert that is received less than three business days prior to the insertion date or is improperly labelled or is received in a damaged condition will be cancelled and/or rescheduled. Any expenses incurred by The Globe and Mail will be charged to the client.

Any insert material remaining after the print run will be recycled immediately after the completion of insertion unless written arrangements are made at least five business days prior to the insertion date with The Globe and Mail. Pick-up must be completed within two business days of the insertion date.

Any cancelled inserts not removed from the plants by the client within three days of cancellation will be recycled unless prior written arrangements for re-scheduling or removal by the client are made. Late cancellation charges up to 50% of the original order will apply to all inserts cancelled less than five days prior to insertion.

### SPOILAGE

Please supply an additional 1.5% for spoilage.

### MULTIPLE VERSIONS

Maximum of two versions per plant. Inserts must be identical in size, number of pages and paper stock. Only content may vary. Product must be separated and clearly labelled prior to delivery to our plants.

### MIXED SPLIT-RUN INSERTS (A-B SPLITS)

Mixed split-run inserts (A-B splits) must arrive pre-mixed and with the correct distribution indicated on the shipment label. Inserts must be identical in size, number of pages and paper stock. Only content may vary.

### SHIPMENT LABELS

All inserts must be labelled with the following information:

- The Globe and Mail
- Client name and Insert title
- Date of insertion
- Total number of inserts shipped
- Number of inserts on each pallet
- Total number of pallets shipped
- Name, address and phone number of printer/shipper
- Name and phone number of client's customs broker (for cross-border shipments)

**Note:** All cross-border shipments should also include a description of goods (printed matter) and the value of the material on the waybill for quicker customs clearance. The client should notify their customs broker prior to shipment.

**Please contact Michael Anderson at 416-585-5455, [mwanderson@globeandmail.com](mailto:mwanderson@globeandmail.com) or Linda Hoefler at 416-585-5856, [lhoefler@globeandmail.com](mailto:lhoefler@globeandmail.com) regarding all production inquiries, cancellations or delivery delays [www.globelink.ca/newspaper/inserts](http://www.globelink.ca/newspaper/inserts).**

## PLANT ADDRESSES AND RECEIVING HOURS

### Toronto Plant

The Globe and Mail  
c/o TC Transcontinental Vaughan  
100B Royal Group Crescent  
North Doors A & B  
Vaughan, Ontario L4H 1X9  
7 AM - 4 PM Monday - Friday

### Estevan Plant

The Globe and Mail  
c/o Estevan Web  
1 Breeze Street, Hwy 39 West  
South East Bay Door  
Estevan, Saskatchewan S4A 2L7  
8 AM - 6 PM Monday - Friday

### Montreal Plant

The Globe and Mail  
c/o TC Transcontinental Transmag  
10807 Rue Mirabeau  
Anjou, Quebec H1J 1T7  
7 AM - 5 PM Monday - Friday

### Calgary Plant

The Globe and Mail  
c/o TC Transcontinental Calgary  
5516 Fifth Street SE  
Calgary, Alberta T2H 1L3  
8 AM - 4:30 PM Monday - Friday

### Halifax Plant

TC Halifax Printing  
Attn: Shipping  
11 Ragged Lake Blvd  
Halifax, NS B3S 1R3  
8:00 AM - 4:00 PM Monday - Thursday  
8:00 AM - 12:00 PM Friday

### Vancouver Plant

The Globe and Mail  
c/o TC Transcontinental Vancouver  
725 Hampstead Close  
Annacis Island  
Delta, B.C. V3M 6R6  
7 AM - 5 PM Monday - Friday  
604-527-9243\*

\*Delivery appointment required





## SHIPPING INSTRUCTIONS – MECHANICAL INSERTS

- All inserts scheduled for mechanical insertion should be supplied bulk on skids and must not be cross-tied. Skids should be loaded (when possible) in equal quantities per skid.
- Two to 36 page inserts printed on glossy or uncoated stock should be stacked in bundles of 4" to 8" in height. Elastic banding and boxes allowed as needed.
- inserts over 36 pages printed on glossy or uncoated stock should be stacked in bundles of 6" to 8" in height. Elastic banding and boxes allowed as needed. No compensation - all spines must be stacked in the same direction.
- Quarterfolded inserts printed on uncoated/newsprint stocks should be stacked in bundles of 4" to 8" high. Single plastic strapping or elastic banding is required on each bundle.
- Unstable inserts over 24 pages Digest sized (or smaller) printed on glossy stock should be supplied stacked in boxes. No plastic strapping allowed on products supplied in boxes. Elastic banding allowed as needed.
- All supplements must be brick stacked with interlocking layers.
- Corner boards should be used to prevent damage to the outside edges of the loaded skid. Life containers are acceptable.
- All inserts must be stacked on pallets in consistent lifts, be well-jogged, and all pallets should be securely banded and plastic stretch-wrapped or shrink-wrapped.
- Stacked inserts should cover pallet and never protrude beyond the edge of the pallet.
- Folded edges should be turned towards the inside of the load whenever possible.
- Product must be stacked on solid base, **48"x40" (industry standard)** non-returnable, four-way entry pallets in good condition. Two-way pallets may be used as needed to accommodate automated compression banding and wrapping equipment.
- A substantial protective cover should be placed on the pallet before stacking and another cover placed before topping.
- Cardboard sheets or binder sheets, not waxed or coated, should be placed between layers.
- Pallet tops must be wood or a sturdy equivalent the same size as the pallet base.
- Banding should be tight without pulling down and bending the top turn or pulling loose the pallet flooring. A minimum of four bands to be on each load.
- Clearance from floor to bottom of pallet base is a minimum of 4 1/2" to maximum of 8".
- Maximum allowable loaded pallet height is 4' measured from floor to pallet top.
- Maximum acceptable weight per loaded pallet is 2,500 pounds.
- Shipment labels and a sample of the insert must be displayed on two adjacent sides of each pallet.
- Pallets must be loaded on the truck so that the pallet tag faces the fork lift operator. Pallets must be loaded on trucks for ease of unloading. Do not "double deck".

### Correctly loaded skids



### Incorrectly loaded skids. Additional costs will apply and damaged copies will not be inserted.





## SHIPPING INSTRUCTIONS – HAND INSERTS/SPECIAL PRODUCTS

### PLEASE NOTE:

THE INSERT MATERIAL DEADLINE IS FIVE BUSINESS DAYS PRIOR TO THE RUN DATE. SHIPMENTS ARRIVING MORE THAN SEVEN BUSINESS DAYS PRIOR TO INSERTION WILL BE REFUSED.

The client should supply the recommended press run amount (plus spoilage) to ensure that all copies of the newspaper are inserted. Please note that our press run numbers can fluctuate on a daily basis due to market activity. The airline copies are not inserted in the Toronto market and these amounts are not included in the press run figures. Contact your sales representative for the latest press run figures.

All quotations exclude freight to The Globe and Mail plants. The client and/or agency will arrange for delivery and prepay all delivery expenses (including any customs brokerage fees).

All insert material must arrive at our printing plants during normal receiving hours no later than three business days prior to the insertion date. No deliveries will be accepted on Saturday, Sunday or statutory holidays.

Insert shipments do not require prior appointments for delivery except for the Vancouver Plant. Please call 604-527-9230 to make an appointment. You must provide the client name, insert title and run date. The shipment must be properly labelled and must arrive at our plants in good condition; otherwise the shipment will not be unloaded.

Any insert that is received less than three business days prior to the insertion date or is improperly labelled or is received in a damaged condition will be cancelled and/or rescheduled. Any expenses incurred by The Globe and Mail will be charged to the client.

Any insert material remaining after the print run will be recycled immediately after the completion of insertion unless written arrangements are made at least five business days prior to the insertion date with The Globe and Mail. Pick-up must be completed within two business days of the insertion date.

Any cancelled inserts not removed from the plants by the client within three days of cancellation will be recycled unless prior written arrangements for re-scheduling or removal by the client are made. Late cancellation charges up to 50% of the original order will apply to all inserts cancelled less than five days prior to insertion.

### SPOILAGE

Please supply an additional 2% for spoilage.

### SHIPMENT LABELS

All inserts must be labelled with the following information:

- The Globe and Mail
- Client name and Insert title
- Date of insertion
- Total number of inserts shipped
- Total number of copies per bundle
- Number of inserts on each pallet
- Total number of pallets shipped
- Name, address and phone number of printer/shipper
- Name and phone number of client's customs broker (for cross-border shipments)

**Note:** All cross-border shipments should also include a description of goods (printed matter) and the value of the material on the waybill for quicker customs clearance. The client should notify their customs broker prior to shipment.

**Please contact Michael Anderson at 416-585-5455, [mwanderson@globeandmail.com](mailto:mwanderson@globeandmail.com) or Linda Hoefler at 416-585-5856, [lhoefler@globeandmail.com](mailto:lhoefler@globeandmail.com) regarding all production inquiries, cancellations or delivery delays [www.globelink.ca/newspaper/inserts](http://www.globelink.ca/newspaper/inserts).**

## PLANT ADDRESSES AND RECEIVING HOURS

### Toronto Plant

The Globe and Mail  
c/o TC Transcontinental Vaughan  
100B Royal Group Crescent  
North Doors A & B  
Vaughan, Ontario L4H 1X9  
7 AM - 4 PM Monday - Friday

### Estevan Plant

The Globe and Mail  
c/o Estevan Web  
1 Breeze Street, Hwy 39 West  
South East Bay Door  
Estevan, Saskatchewan S4A 2L7  
8 AM - 6 PM Monday - Friday

### Montreal Plant

The Globe and Mail  
c/o TC Transcontinental Transmag  
10807 Rue Mirabeau  
Anjou, Quebec H1J 1T7  
7 AM - 5 PM Monday - Friday

### Calgary Plant

The Globe and Mail  
c/o TC Transcontinental Calgary  
5516 Fifth Street SE  
Calgary, Alberta T2H 1L3  
8 AM - 4:30 PM Monday - Friday

### Halifax Plant

TC Halifax Printing  
Attn: Shipping  
11 Ragged Lake Blvd  
Halifax, NS B3S 1R3  
8:00 AM - 4:00 PM Monday - Thursday  
8:00 AM - 12:00 PM Friday

### Vancouver Plant

The Globe and Mail  
c/o TC Transcontinental Vancouver  
725 Hampstead Close  
Annacis Island  
Delta, B.C. V3M 6R6  
7 AM - 5 PM Monday - Friday  
604-527-9243\*

\*Delivery appointment required



## SHIPPING INSTRUCTIONS – HAND INSERTS/SPECIAL PRODUCTS

### BUNDLING CHART

**HAND-INSERTS** (2 - 24 pages) - cross-tied in bundles of 50

**HAND-INSERTS** (over 24 pages) - cross-tied in bundles of 20

**OUTSERTS** - supplied cross-tied in bundles of 50

**POST-IT NOTES** - supplied in pads of 50

**SLEEVES** - banded in bundles of 100

**TAGS** - banded in bundles of 50

**Note:** Maximum bundle weight: 25 lbs.

- Corner boards should be used to prevent damage to the outside edges of the loaded skid. Life containers are acceptable.
- All inserts must be stacked on pallets in consistent lifts, be well-jogged, and all pallets should be securely banded and plastic stretch-wrapped or shrink-wrapped.
- Stacked inserts should cover pallet and never protrude beyond the edge of the pallet.
- Product must be stacked on solid base, **48"x40" (industry standard)** non-returnable, four-way entry pallets in good condition. Two-way pallets may be used as needed to accommodate automated compression banding and wrapping equipment.
- A substantial protective cover should be placed on the pallet before stacking and another cover placed before topping.
- Cardboard sheets or binder sheets, not waxed or coated, should be placed between layers.
- Folded edges should be turned towards the inside of the load whenever possible.
- Pallet tops must be wood or a sturdy equivalent the same size as the pallet base.
- Banding should be tight without pulling down and bending the top turn or pulling loose the pallet flooring. A minimum of four bands to be on each load.
- Clearance from floor to bottom of pallet base is a minimum of 4 1/2" to maximum of 8".
- Maximum allowable loaded pallet height is 4' measured from floor to pallet top.
- Maximum acceptable weight per loaded pallet is 2,500 pounds.
- Shipment labels and a sample of the insert must be displayed on two adjacent sides of each pallet.
- Pallets must be loaded on the truck so that the pallet tag faces the fork lift operator. Pallets must be loaded on trucks for ease of unloading. Do not "double deck".

Please contact Michael Anderson at 416-585-5455, [mwanderson@globeandmail.com](mailto:mwanderson@globeandmail.com) or Linda Hoefler at 416-585-5856, [lhoefler@globeandmail.com](mailto:lhoefler@globeandmail.com) regarding all production inquiries, cancellations or delivery delays [www.globelink.ca/newspaper/inserts](http://www.globelink.ca/newspaper/inserts).



## CONTACT US

---

### ADVERTISING INSERTS

#### TORONTO ONTARIO & MANITOBA

TEL: 1-800-387-9012 EMAIL [advertising@globeandmail.com](mailto:advertising@globeandmail.com)

#### EASTERN CANADA OTTAWA REGION, QUÉBEC, & ATLANTIC CANADA

TEL: 1-800-363-7526 EMAIL [advertisingeasternca@globeandmail.com](mailto:advertisingeasternca@globeandmail.com)

#### BRITISH COLUMBIA

TEL: 1-800-663-1311 EMAIL [advertisingwesternca@globeandmail.com](mailto:advertisingwesternca@globeandmail.com)

#### NORTHWEST TERRITORIES & NUNAVUT

TEL: 1-604-685-0308 EMAIL [advertisingwesternca@globeandmail.com](mailto:advertisingwesternca@globeandmail.com)

#### ALBERTA & SASKATCHEWAN

TEL: 1-403-245-4987 or 1-403-774-8024 EMAIL [advertisingwesternca@globeandmail.com](mailto:advertisingwesternca@globeandmail.com)

#### UNITED STATES & WORLDWIDE

TEL: 1-212-946-0219 EMAIL [globeandmail@publicitas.com](mailto:globeandmail@publicitas.com)

### THIRD PARTY AD MAGAZINES

Michael Anderson TEL: 416-585-5455 EMAIL [mwanderson@globeandmail.com](mailto:mwanderson@globeandmail.com)

Linda Hoefler TEL: 416-585-5856 EMAIL [lhoefler@globeandmail.com](mailto:lhoefler@globeandmail.com)

### GLOBELINK.CA

CONTACT DIRECTORY

[GLOBELINK.CA/DIRECTORY](http://GLOBELINK.CA/DIRECTORY)

INSERT INFORMATION

[GLOBELINK.CA/NEWSPAPER/INSERTS](http://GLOBELINK.CA/NEWSPAPER/INSERTS)

**YOU ALSO NEED TO KNOW:** Any advertising published by The Globe and Mail in the newspaper or any of its other publications may, at our discretion, be published, displayed, retained and archived by us and anyone authorized (including any form of licence) by us, as many times as we and those authorized by us wish, in or on any product, media and archive (including print, electronic and otherwise).

All advertising must meet Globe and Mail terms and conditions, available on [gobelink.ca/termsandconditions](http://gobelink.ca/termsandconditions), on the previous page, or please request a printed copy from your Globe and Mail representative.