

MECHANICAL INSERT SPECS AND SHIPPING INSTRUCTIONS

2015.16 Concert Season

The Royal Conservatory

Advanced winter weaponry
The proliferation of snowfall gadgets - from launchers to blasters to snowbombs - has altered the seasonal snow-fact landscape.

THE GLOBE AND MAIL
CANADA'S NATIONAL NEWSPAPER • TUESDAY, DECEMBER 15, 2015 • globeandmail.com

Fed rate hike first since economic crisis

With 0.25-per-cent increase signals confidence in emerging U.S. economy that could translate into a boost for Canadian exports

MEANWHILE The U.S. Federal Reserve on Tuesday raised its benchmark rate for the first time since 2007, a move that will prompt a rise in mortgage rates and other borrowing costs. The move is seen as a sign of confidence in the U.S. economy, but it also raises concerns about the impact on the Canadian dollar and exports.



ORCA WITNESS A group of orcas in British Columbia waters, including one that was seen breaching.

GOING COASTAL

After tracking water during the Harper era, Canada's marine conservation effort is drifting into high gear. The new Liberal government has confirmed that it will set aside 85 per cent of the country's marine waters for protection by 2020 to meet commitments under the UN Convention on Biodiversity.

Quake confirmed as largest caused by fracking in B.C.

A 5.1 magnitude earthquake on Tuesday in British Columbia was confirmed as the largest ever caused by hydraulic fracturing in the province. The quake occurred near the town of Hazelton.

Canadian laser begins trek to scope asteroid

A Canadian laser system is set to begin its journey to a distant asteroid in the next few weeks. The mission is part of a larger project to study the asteroid's composition.

SECURE The U.S. State Department has announced that it will provide more information about the cyberattacks on the U.S. Treasury Department.

POWER YOU WANT. ROOM YOU NEED.

THE 2016 Acura MDX. STARTING FROM \$22,991*

MDX

CNE GUIDEBOOK 2015

BASKETS
Innovative. Intelligent. Irresistible.

DELL

Great ideas have big.

Inspired (15.6" Ultra Slim) \$549.99*

RONA HOME & GARDEN

EXFL
AGA KHAN MUSEUM

GET UP TO 20% OFF
ON THE PURCHASE OF SPECIAL ORDER KITCHEN CABINETS



MECHANICAL INSERT SPECIFICATIONS

Minimum Size: 4" wide x 7" deep.

Maximum size: 10" wide x 10.5" deep.

Maximum Weight: Up to 220 grams for a mechanical insert.

Larger products may be hand inserted for an additional charge.

Maximum number of pages for all digest size inserts is 32 pages.

MINIMUM PAPER WEIGHT

Number of Pages

2 pages	7 pt. card stock
4 pages	70 lb stock
6 pages	60 lb stock
8 pages	50 lb stock
12+ pages	45 lb stock

Note: All newsprint products must be a minimum of 8 pages on 30 lbs stock or heavier and must be quarter-folded. All trimmed booklets must be quarterfolded, stitched or bound to prevent product separation during insertion. Inserts must have one closed edge to ensure proper insertion by our equipment. We do not accept accordion-style or plastic wrapped inserts for mechanical insertion. All inserts with perforations or die cuts must be tested prior to insertion.

MINIMUM SIZE

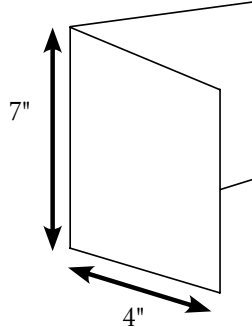

MAXIMUM SIZE

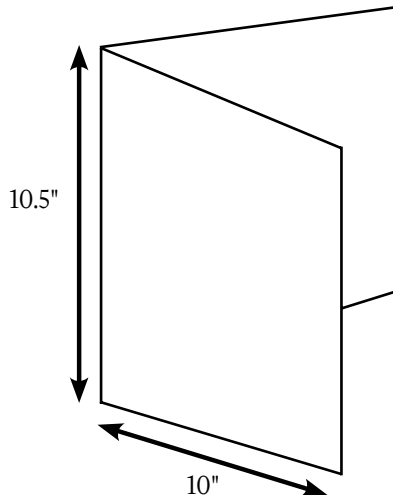

Coatings

Please note: certain AQ (Aqueous) coatings, such as SOFT TOUCH, that create a wax-like finish when applied while printing inserts intended for mechanical insertion may cause feeding problems on our inserting machines and possible production delays. These coated products tend to stick together and may result in multiple copies being inserted into the newspaper. In addition, some high gloss UV (ultra-violet) coatings may cause the opposite result by creating a slippery product that may slide easily out of the newspaper during insertion or delivery. If any insert or magazine product creates production problems or delays that would result in a reduced delivery efficiency of the Globe and Mail, we reserve the right to remove the product from insertion. The Globe and Mail will promptly notify the client of any such circumstances and a new distribution date will be established at that time. Pricing will remain firm in the event of such an occurrence. If you are unsure about the coating on your insert, please check with your printer and have them send at least five stock samples with the intended coating to The Globe and Mail for review.

Blow-In Inserts

Supplied inserts cannot contain blow-in inserts.

Envelopes

Envelopes cannot be less than 5" deep x 7" wide. Envelope contents must be of a uniform size and the envelope must be sealed.

Scented Inserts

Sales representatives with customers wanting to insert scented products must notify Michael Anderson at 416-585-5455 or email mwanderson@globeandmail.com.

Samples/Mock-Ups

All insert reservations must be accompanied by a mock-up or sample for approval within two weeks of booking. Any insert reservation that does not have an approved mock-up or sample provided is subject to cancellation anytime after two weeks from the date of booking. The mock-up does not have to be printed, but must be on the same paper stock, and be trimmed and folded to the final size of the insert. The sample can be either the final printed version of the insert or a copy of a previously inserted product that was approved for mechanical insertion. If your insert is a repeat of the same design and size of a previously approved insert, you must provide the run date of the previous insert in order to confirm your order.

All insert samples/mock-ups should be sent to:

Michael Anderson
c/o The Globe and Mail,
444 Front Street West
Toronto, Ontario M5V 2S9

Please include a contact name, phone number and email address with your sample. Inserts that do not meet our specifications may be hand inserted for home delivery only. An additional handling fee will apply.



STANDARD MECHANICAL INSERT DESIGNS

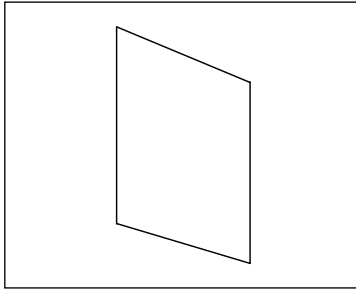

2 PAGE – NO FOLD
FLAT SINGLE SHEET
MINIMUM PAPER STOCK: 7 PT CARD STOCK

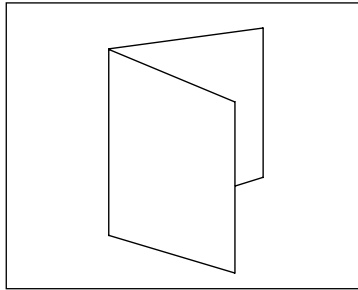

4 PAGE – ONE FOLD
SIMPLE FOLD
MINIMUM PAPER STOCK: 70 LBS

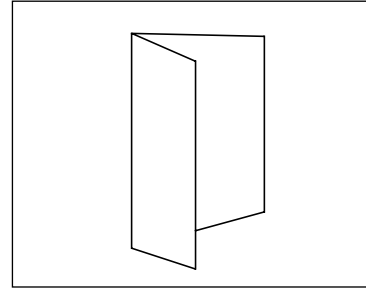

4 PAGE – ONE FOLD
SHORT FOLD (MINIMUM 4")
MINIMUM PAPER STOCK: 70 LBS

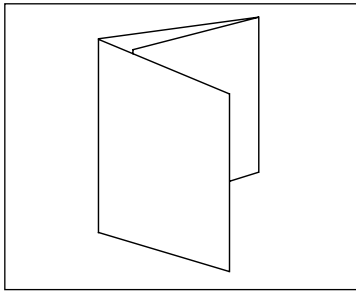

6 PAGE – TWO FOLDS
BARREL/LETTER FOLD
MINIMUM PAPER STOCK: 60 LBS

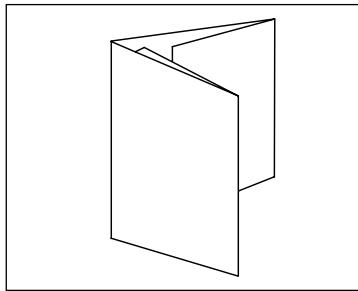

8 PAGE – THREE FOLDS
GATEFOLD
MINIMUM PAPER STOCK: 50 LBS

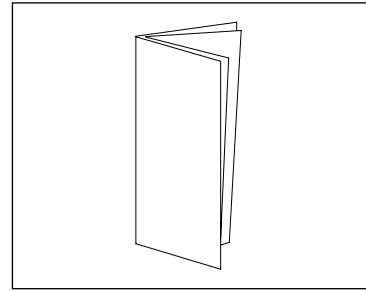

8 PAGE – TWO FOLDS
SIGNATURE/BOOKLET
MINIMUM PAPER STOCK: 50 LBS

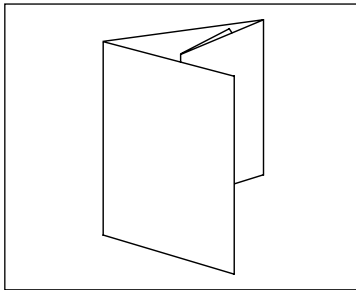

8 PAGE – THREE FOLDS
ROLL FOLD
MINIMUM PAPER STOCK: 50 LBS

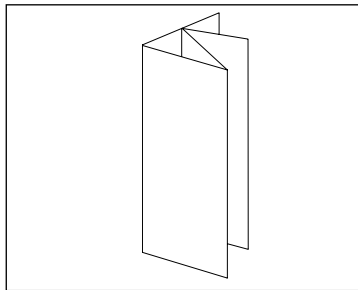

8 PAGE – THREE FOLDS
PARALLEL FOLD
MINIMUM PAPER STOCK: 50 LBS

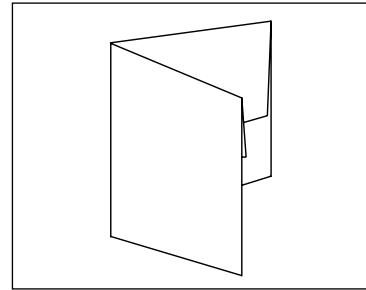

8 PAGE – TWO FOLDS
FRENCH FOLD
MINIMUM PAPER STOCK: 50 LBS

UNACCEPTABLE MECHANICAL INSERT DESIGNS

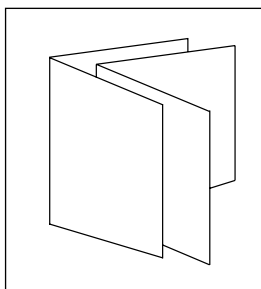

LOOSE BOOKLET

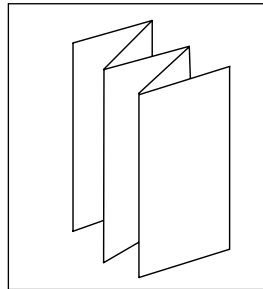

ACCORDION FOLD

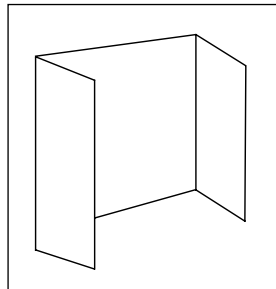

OPEN GATEFOLD

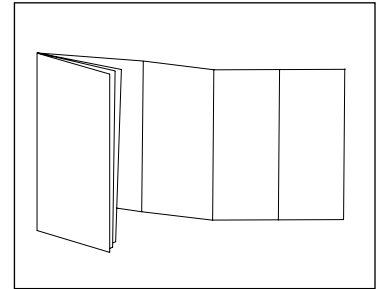

MULTIPLE COVER GATEFOLD



SHIPPING INSTRUCTIONS – MECHANICAL INSERTS

PLEASE NOTE:

THE INSERT MATERIAL DEADLINE IS FIVE BUSINESS DAYS PRIOR TO THE RUN DATE. SHIPMENTS ARRIVING MORE THAN SEVEN BUSINESS DAYS PRIOR TO INSERTION WILL BE REFUSED.

The client should supply the recommended press run amount (plus spoilage) to ensure that all copies of the newspaper are inserted. Please note that our press run numbers can fluctuate on a daily basis due to market activity. The airline copies are not inserted in the Toronto market and these amounts are not included in the press run figures. Contact your sales representative for the latest press run figures.

All quotations exclude freight to The Globe and Mail plants. The client and/or agency will arrange for delivery and prepay all delivery expenses (including any customs brokerage fees).

All insert material must arrive at our printing plants during normal receiving hours no later than three business days prior to the insertion date. No deliveries will be accepted on Saturday, Sunday or statutory holidays.

Insert shipments do not require prior appointments for delivery except for the Vancouver Plant. Please call 604-527-9230 to make an appointment. You must provide the client name, insert title and run date. The shipment must be properly labelled and must arrive at our plants in good condition; otherwise the shipment will not be unloaded.

Any insert that is received less than three business days prior to the insertion date or is improperly labelled or is received in a damaged condition will be cancelled and/or rescheduled. Any expenses incurred by The Globe and Mail will be charged to the client.

Any insert material remaining after the print run will be recycled immediately after the completion of insertion unless written arrangements are made at least five business days prior to the insertion date with The Globe and Mail. Pick-up must be completed within two business days of the insertion date.

Any cancelled inserts not removed from the plants by the client within three days of cancellation will be recycled unless prior written arrangements for re-scheduling or removal by the client are made. Late cancellation charges up to 50% of the original order will apply to all inserts cancelled less than five days prior to insertion.

SPOILAGE

Please supply an additional 1.5% for spoilage.

MULTIPLE VERSIONS

Maximum of two versions per plant. Inserts must be identical in size, number of pages and paper stock. Only content may vary. Product must be separated and clearly labelled prior to delivery to our plants.

MIXED SPLIT-RUN INSERTS (A-B SPLITS)

Mixed split-run inserts (A-B splits) must arrive pre-mixed and with the correct distribution indicated on the shipment label. Inserts must be identical in size, number of pages and paper stock. Only content may vary.

SHIPMENT LABELS

All inserts must be labelled with the following information:

- The Globe and Mail
- Client name and Insert title
- Date of insertion
- Total number of inserts shipped
- Number of inserts on each pallet
- Total number of pallets shipped
- Name, address and phone number of printer/shipper
- Name and phone number of client's customs broker (for cross-border shipments)

Note: All cross-border shipments should also include a description of goods (printed matter) and the value of the material on the waybill for quicker customs clearance. The client should notify their customs broker prior to shipment.

Please contact Michael Anderson at 416-585-5455, mwanderson@globeandmail.com or Linda Hoefler at 416-585-5856, lhoefler@globeandmail.com regarding all production inquiries, cancellations or delivery delays www.globelink.ca/newspaper/inserts.

PLANT ADDRESSES AND RECEIVING HOURS

Toronto Plant

The Globe and Mail
c/o TC Transcontinental Vaughan
100B Royal Group Crescent
North Doors A & B
Vaughan, Ontario L4H 1X9
7 AM - 4 PM Monday - Friday

Estevan Plant

The Globe and Mail
c/o Estevan Web
1 Breeze Street, Hwy 39 West
South East Bay Door
Estevan, Saskatchewan S4A 2L7
8 AM - 6 PM Monday - Friday

Montreal Plant

The Globe and Mail
c/o TC Transcontinental Transmag
10807 Rue Mirabeau
Anjou, Quebec H1J 1T7
7 AM - 5 PM Monday - Friday

Calgary Plant

The Globe and Mail
c/o TC Transcontinental Calgary
5516 Fifth Street SE
Calgary, Alberta T2H 1L3
8 AM - 4:30 PM Monday - Friday

Halifax Plant

TC Halifax Printing
Attn: Shipping
11 Ragged Lake Blvd
Halifax, NS B3S 1R3
8:00 AM - 4:00 PM Monday - Thursday
8:00 AM - 12:00 PM Friday

Vancouver Plant

The Globe and Mail
c/o TC Transcontinental Vancouver
725 Hampstead Close
Annacis Island
Delta, B.C. V3M 6R6
7 AM - 5 PM Monday - Friday
604-527-9243*

*Delivery appointment required



SHIPPING INSTRUCTIONS – MECHANICAL INSERTS

- All inserts scheduled for mechanical insertion should be supplied bulk on skids and must not be cross-tied. Skids should be loaded (when possible) in equal quantities per skid.
- Two to 36 page inserts printed on glossy or uncoated stock should be stacked in bundles of 4" to 8" in height. Elastic banding and boxes allowed as needed.
- inserts over 36 pages printed on glossy or uncoated stock should be stacked in bundles of 6" to 8" in height. Elastic banding and boxes allowed as needed. No compensation - all spines must be stacked in the same direction.
- Quarterfolded inserts printed on uncoated/newsprint stocks should be stacked in bundles of 4" to 8" high. Single plastic strapping or elastic banding is required on each bundle.
- Unstable inserts over 24 pages Digest sized (or smaller) printed on glossy stock should be supplied stacked in boxes. No plastic strapping allowed on products supplied in boxes. Elastic banding allowed as needed.
- All supplements must be brick stacked with interlocking layers.
- Corner boards should be used to prevent damage to the outside edges of the loaded skid. Life containers are acceptable.
- All inserts must be stacked on pallets in consistent lifts, be well-jogged, and all pallets should be securely banded and plastic stretch-wrapped or shrink-wrapped.
- Stacked inserts should cover pallet and never protrude beyond the edge of the pallet.

- Folded edges should be turned towards the inside of the load whenever possible.
- Product must be stacked on solid base, **48"x40" (industry standard)** non-returnable, four-way entry pallets in good condition. Two-way pallets may be used as needed to accommodate automated compression banding and wrapping equipment.
- A substantial protective cover should be placed on the pallet before stacking and another cover placed before topping.
- Cardboard sheets or binder sheets, not waxed or coated, should be placed between layers.
- Pallet tops must be wood or a sturdy equivalent the same size as the pallet base.
- Banding should be tight without pulling down and bending the top turn or pulling loose the pallet flooring. A minimum of four bands to be on each load.
- Clearance from floor to bottom of pallet base is a minimum of 4 1/2" to maximum of 8".
- Maximum allowable loaded pallet height is 4' measured from floor to pallet top.
- Maximum acceptable weight per loaded pallet is 2,500 pounds.
- Shipment labels and a sample of the insert must be displayed on two adjacent sides of each pallet.
- Pallets must be loaded on the truck so that the pallet tag faces the fork lift operator. Pallets must be loaded on trucks for ease of unloading. Do not "double deck".

Correctly loaded skids



Incorrectly loaded skids. Additional costs will apply and damaged copies will not be inserted.

